



Auxiliar 2

Controlemos un motor!

Curso: Mecatrónica - ME4250

Profesora: Carolina Silva

Auxiliar: Makarena Torres



Para hoy

01



Mini repasito

02

Ejercicio 1

03

**Espacio para su
diseño**





01

Mini repasito



Arduino IDE - ¿Dudas?



The screenshot shows the Arduino IDE interface. The window title is "sketch_mar26a | Arduino 1.8.12". The toolbar includes icons for check, run, file, upload, and download. The sketch editor shows the following code:

```
sketch_mar26a
void setup() {
  // put your setup code here, to run once:
}
void loop() {
  // put your main code here, to run repeatedly:
}
```

Aquí corre 1 vez

Aquí corre en bucle

<https://www.arduino.cc/en/software>

Dudas de código



Correo



arduino.cc

<https://forum.arduino.cc>

Arduino Forum

Topics about **Arduino** boards, shields and kits. 1898. Software. 0. Community. 0. Development.

0. International. 0. **Forum** 2005-2010 (read only).

Latest Español topics

... interacción con otro hardware solo para Arduinos ATMEL o ...

<https://forum.arduino.cc/>



ChatGPT



Motor DC

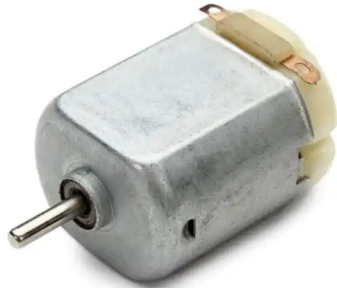

Sin reducción



Con reducción

Puente H

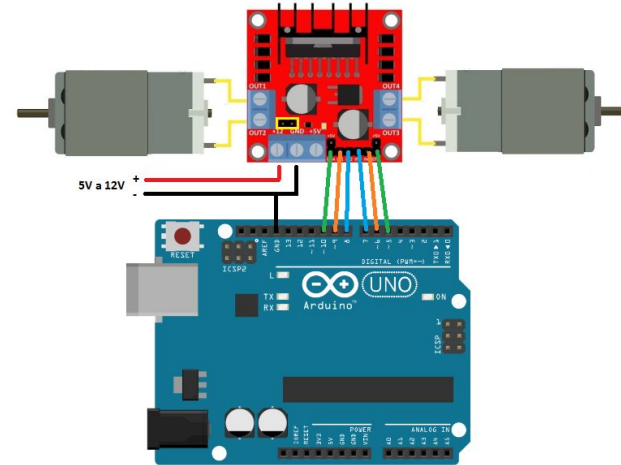
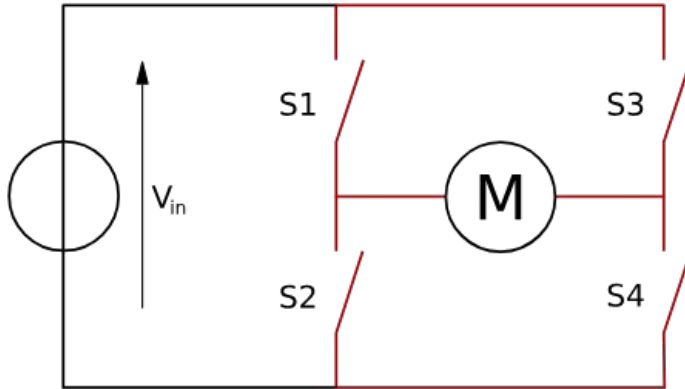
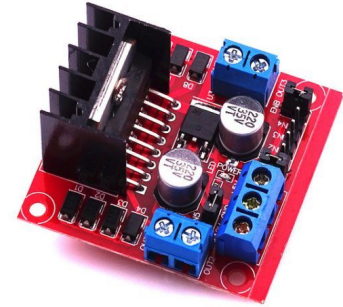

Servomotor

Microservo



Ambos
180°

0

360°

Servo

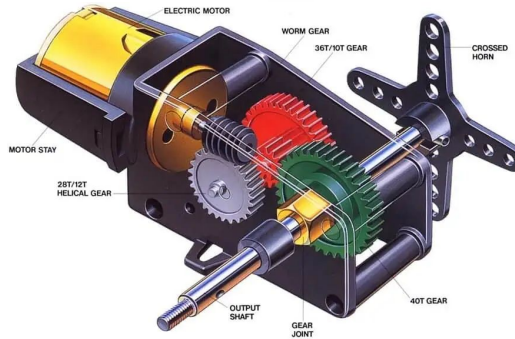

Construction of Servo Motor



Motor stepper



Donde comprar

mechatronic
STORE CL

<https://www.mechatronicstore.cl/>

San Diego - varios



<https://www.instagram.com/electronicahobby/>



02

Ejercicio 1

Controlar el servomotor con botones y/o monitor serial

Duración: 45 minutos

Algunas ideas:

- Mantener presionado un botón para que gire
- Escribir la cantidad de grados que debe girar el servomotor



03

**Espacio para sus
proyectos**



AUTODESK
Tinkercad

Tinkercad

Únete a **Mecatrónica - ME4250** con un vínculo o introduce este código de clase:

EMK GXP 7Q8



Gracias <3